

THE QUARTERLY

Official Publication of the St. Lawrence County Historical Association

E. Badlam,

April 1980

Piano Attachment

N^o 4,241.

Patented Oct. 25, 1845.

Fig. 1.

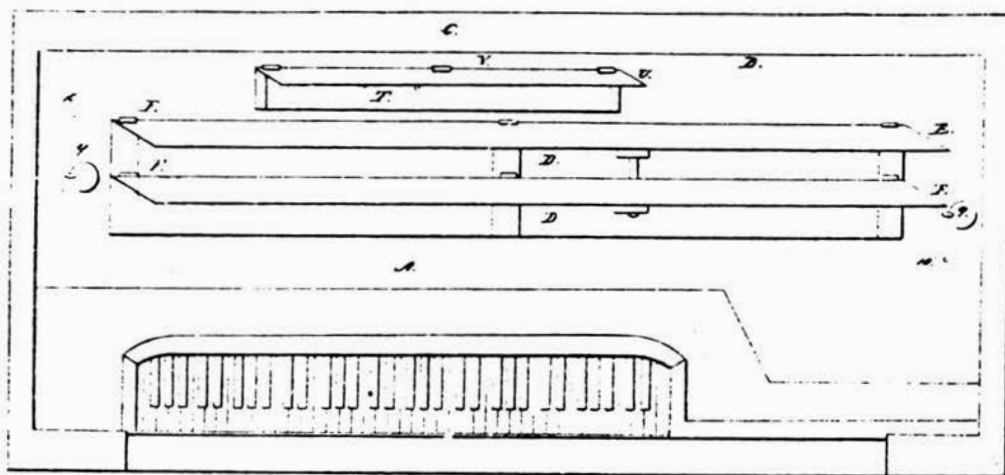

Fig. 3.

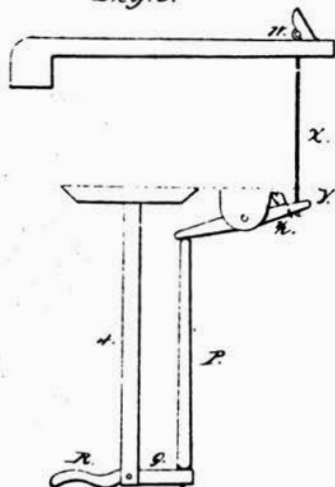
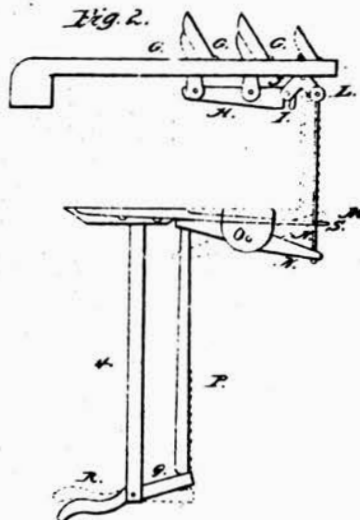

Fig. 2.



Commemorative Issue

OUR TWENTY-FIFTH YEAR OF PUBLICATION

THE QUARTERLY

Official Publication of the St. Lawrence County Historical Association

VOLUME XXV

APRIL 1980

NO. 2

CONTENTS

- | | | |
|---|----|--|
| <i>Rosabel Parker Meashaw</i> | 3 | Bearing the Stigma of Temperance |
| <i>John A. Baule and
Mary Ruth Beaman</i> | 6 | Edward Badlam: Inventor of Note |
| <i>Eleanor Dumas and
Nina Dumas</i> | 11 | 'A Village Today—A City Tomorrow' |
| <i>Varick A. Chittenden
editor</i> | 13 | "... a good country for a poor man to come to with a family": the
Smith Family Letter |
| | 18 | Food for the Hungry... Drink for the Thirsty... Rest for the Weary |
| <i>Pauline Tedford</i> | 22 | The Bridge Built by Three Towns |
| <i>Mary Ruth Beaman</i> | 23 | The Wright Corner |

The Quarterly is published in January, April, July and October each year by the St. Lawrence County Historical Association.

As a courtesy to authors and the editor, the Association asks anyone wishing to reproduce all or part of material included in *The Quarterly* to submit a specific request in writing at least 30 days in advance of its anticipated use.

Extra copies may be obtained from the History Center, P.O. Box 8, Canton, N.Y. 13617, at \$2.00 plus 25¢ postage and handling.

Editor: Varick A. Chittenden

*This publication is made possible in part with public funds from
the New York State Council on the Arts.*

Cover: Patent drawing for modification of a piano, submitted to U.S. Patent office by Edward Badlam of Potsdam. See story beginning on page 6. (Courtesy of John A. Baule)



Present day aerial view of Parker-Meashaw farm at Parishville Centre. Sons of Temperance Hall is the annex to the house. (Photo courtesy of author)

Bearing the Stigma of Temperance

by Rosabel Parker Meashaw

Reflecting on the recent article in The Quarterly on the temperance movement ("In Search of Ardent Spirits: the WCTU," by Mary H. Smallman, October 1979), the author recalls family stories of the formation of the Centre Division #348 of the Sons of Temperance and then reminisces about the impact on her own life of those stories and the old Temperance Hall. In this personal essay laced with the facts of social history, Ms. Meashaw breathes life and charm into the old building on her family farm.

I grew up in and about a "Sons of Temperance" Hall and it marked me for life.

My great-grandfather, Jonas Parker, settled at Parishville Centre in 1824, bringing his family and all of his "worldly possessions" from Hubbardston, Vt. on one ox-drawn and one horse-drawn sled. His sons helped to chop his farm out of the wilderness, and built a

log shanty leaned against a small hill, slabbed down to form the back wall. Later they found a clay bed, molded and burned the brick for the house now owned and occupied by Jack Keener. As each boy in the family reached his majority he was given a stipulated sum for his accumulated earnings. In the early 1830's my grandfather, John Wesson Parker, put his allowance as a

down payment toward the \$750.00 cost of the farm where we still live. He then went back to Vermont to work for the Conant Iron Works of Forestdale and Brandon. Grandpa's oldest brother managed his farm and this end of an agency for Conant Iron Products, mostly stoves, turning all profits toward payment of a land contract. Mission accomplished, my grandparents in 1850

moved here and in 1852 received their deed (which we still treasure) signed with a John Hancock flourish "George Parish by Joseph Rofseel, his Attorney." We also have one bill of stoves listing 14 stoves (\$351.00), 2 plows (\$15.00), 1 pr. sadirons (.82), 1 goose (a heavy tailor's iron) (\$1.50), and small et cetera to a total of \$383.97 shipped by train from Orwell, Vt., Aug. 20, 1844, with instructions "You must have a good length to your wagon boxes." The above merchandise was met at Plattsburgh by two teams which delivered same to Parishville Centre, no date recorded.

In 1836 Allen Whipple bought the farm directly across from ours and in 1840 built the house now owned and occupied by Steven Snell. Our house is eight years the senior and the two old cronies sit facing each other across Route 72, their outer construction still as original, stout and strong.

Allen Whipple always devoted himself to his community, serving in several public offices and winning the respect of all, even the boys of the vicinity. Papa remembered him as "The Old Squire" and had many stories as—the melon patch he set aside especially for the boys, the sweet cherry trees he planted across his west line fence for them, all in interest of preventing pilfering. I can remember picking the luscious cherries from the old and rather scraggly trees—just a few to eat, by my father's orders.

Parishville reaped its early livelihood largely from its rye fields, fields that, with poor management became wasteland known as Parishville Sand but for some years the rye and other grains had become mash which in turn became whiskey and, in many cases, became men's downfall. The Old Squire, my grandparents and others of a temperate persuasion wished to eradicate Demon Rum so organized the "Centre Division #348 of the Sons of Temperance." Whipple and Parker further devised a plan whereby Grandpa would furnish the materials for a two story woodshed, carriage house, etc., affixed to the rear of our dwelling, if the "Sons" would join in the grading, carpentering and raising; the Organization could use the second story for their club rooms. This was accomplished in the early 1850's.

In the old minute book we read various names dropped from the roster, whether from satisfying a lingering thirst or nonpayment of dues it does not state. Eventually the Division disbanded, dividing the furnishings among the still faithful members. The building, being nailed to our house, became ours.

My grandfather died in 1884 leaving son Byron to care for the farm and his mother. High priority had always been given to keeping up the buildings so the annex was kept roofed and painted, but the interior passed through several



Photo. by Stone, Potsdam.

Allen Whipple

Allen Whipple—"the Old Squire"—of Parishville Centre as he appeared in Evert's history of St. Lawrence County in 1878. (Courtesy of the History Center Archives)

stages: harness repair and tinker shop, grain storage, repository for relatives' and neighbors' treasures when they moved West, things they hated to throw away when they could store them free and come back for them later; (ed. note) they never did. It made a gorgeous place for the younger generation to play.

About 1920 the neighbors again rallied, cleaned up the old hall, shored up the underpinning, built a fire escape—and lo!—we were a Community Center. Suppers were served at 25¢ each (later 35¢) by the ladies interested in improving our local Chapel Hill Cemetery. Dances were fiddled by Johnnie Russell, chorded by his sister and others, called by Clarence Chrystal; adults waltzed, reeled and squared to purchase an iron fence for the two road sides of the

cemetery. Their children slept peacefully on the tables, cushioned by coats, in the little room across the entry, no need for babysitters in those days; district teachers held box socials to raise money for library books and other luxuries too expensive for the taxpayers.

Of course these activities were all in Prohibition times so the only temperance enforcement necessary was patrolling the yard at intervals to search and destroy any jug of home-brew. My father, a medium sized man, said he always took a larger man with him to look tall while he talked—"No Booze!" He always said if he had to call the troopers—as some local halls did—that would be the last dance in Parker's Hall. We also had many sleigh ride groups from the Potsdam colleges and churches,

complete with chaperones. It was after my father's death that we agreed to let one of the college fraternities use the hall for the evening, no rowdies, no vandals and they invited us to join them, but when they rolled in the kegs of beer, I felt I had betrayed a trust and that was the last dance.

But here was Temperance again falling into step with me, right in the heart of the wicked city. I applied on Wednesday and was told I could start work next morning—stuffing envelopes with temperance literature and directing to Christian Science Practitioners all over the section. Oh, the things we study Latin derivatives and Shakespeare sonnets for! but I stuffed manfully. Came Saturday, would I like my three days salary now or held to combine with next week's pay? Oh, please, kind sir, now, so we ate fresh tomato sandwiches for supper and laid aside the can opener.

My boss was an Italian Methodist minister who spoke words like "therapeutic", "cirrhosis", etc., with a definite accent, expecting me to write them in shorthand and spell them in English. I had to show up well in some other aspect of the business. Oh, yes, I had finished the stuffing and been promoted to letter writing. Now I spent my noon hours (and saved my lunch money) working with the clipping files in their library, one wall of filing cabinets as high as my shoulder, draws crammed at random with information that Mr. Corradini was apt to want in a minute. I clipped, trimmed, mounted and cross indexed. Came that day when Mr. C. called out "Please get that clipping about the shoot out on Second Ave." I turned to my list and knew in nothing flat. It was not filed under "S" for shoot, nor "G" for Gang Activities but right at my fingertip, "D" for drunkenness. Mr. C. forgot his hurry, asked to see and share my index, gave me a big hand and a \$2.00 per week raise! Aside from that my reading had given me such a broad view of the atrocious attacks of alcohol on anatomy, activity and mental ability that I would scarcely even use camphor on a cold sore.

I typed many a manuscript and lecture, five copies deep and no strikeouts! One lady two floors down was high up in WCTU work but a volunteer, no allowance for hiring help, when her pen hand gave out. I was donated to her for a few hours of typing. Would that Aunt Jane could have lived to see me!

Now the old hall has deteriorated to the point the last bent is being threatened with being torn down in the spring, roof still good but last wall largely hole—and I am the last mourner.

But even during the years I was working away from home, I still bore the stigma of Temperance, implanted by the legend of the old hall, aided and abetted by my Aunt Jane, Mama's oldest

sister who lived with us summers. She was a strict Baptist and a dedicated member of the W.C.T.U., Potsdam unit, I think. Her white ribbon was as important a bit of attire as her calico dress and her starched white apron when I sat at her knee.

In June 1928 I went to New York City (1) to get an office job for the summer or (2) failing that, attend summer session at New York University. Either way I was to stay with Aunt Jane's daughter in Greenwich Village. Of course Lavinia was family and had had the advantages of Aunt Jane's early training (two big OK's) but she had gone Bohemian—smoked Tareytons, took lessons twice a week at Mme. Povitch's School of Ballet and drank sweet wine at Christmas. She gave me a slight push that landed me in a delightful job (no longer could be credited with a position). I loved it! My two bosses were witty Irishmen (Murphy and Gilmore). I was bookkeeper, secretary, errand girl and rush hour cajoler to the rich customer who might have to wait a boring minute or two until Mr. M. or Mr. G. finished his sale. We were a Luggage EXCLUSIVELY Store practically in the shade of Cartier's clock. Beautiful Isle of Manhattan but my poor mother was practically a nervous wreck. My father advised that she should have confidence in the job they'd done in bringing me up.

Unfortunately, 1929 followed 1928 and came that fateful October 29. The world slid down hill fast but I clung to the wreckage until August 1930, then slid with it. I took a two month course to learn shorthand and speed up my typing. The squirrel in my soul had made me put by a few staples in Lavinia's cupboard so I broke my last dollar bill to buy 2¢ postage to write a "Please send me" letter home, then went to see the placement director at the school.

The director took a good look at me, criticized me for not wanting to teach, then admitted he, too, had left that profession and sent me to the "Alcohol Information Committee" office in the Methodist Publication Building, 150 Fifth Avenue, N.Y.C. What could be more fitting and pure? The office was sponsored by Irving Fisher, the financial expert who had been prophesying that business would spiral onward and upward indefinitely.

As finances tightened, the other girls in the outer office, typist, switchboard operator, receptionist, were let go, each in her turn. My desk was turned at an angle so I could see the outer door, smile sweetly just in case someone might wish to buy a publication or make a donation, reach the switchboard for inner office calls and type like mad when left to myself. All this a mark of their high regard for me? No. I was the last one

hired and at a lower salary but I did get another \$2.00 raise with each new responsibility. And, altogether, I must have defeated millions of the Demons of Rum.

I might here note my two attempts at depravity:

First an older Woman of the World, shocked at our naivete, invited Eleanor and me to dinner at a Greenwich Village speak-easy—the usual under apartment house stairway entrance, complete with peep hole and password. This admitted to a hot, dark, smoke-filled room, tables crammed into the dimness. We managed until Eleanor said, "Pst!" and pointed to her salad. There sat a fat green worm an inch or more long clinging to the top lettuce leaf with his four sets of back legs, wagging his fat head from side to side at us, "For shame, for shame!" We drank not, neither did we eat, and our hostess dropped us right there—saved by a worm!

Second episode, a new group invited us to go to a tavern over in Jersey. Common sense cautioned but, after months of subways a ride in a convertible cut our resistance. To our country eyes the "Tavern" looked like a maple sugar shanty in front of a sunrise, but that was the place all right. We turned down a driveway at the side, parked and walked into the sunrise. The whole backyard was strung with high powered lights shining on sickly looking sod and sloppy tables. Beer was brought on in pitchers and all spills left to drip or dry as they saw fit. Eleanor and I spent our evening wondering how much protection money the Revenuers harvested here and if we would get back home alive. We did, and there again, were dropped. Monday morning saw our docile selves back on the subway.

The Depression Debacle rolled on in the city but I was spared the worst of it by a much larger one at home. My father died, leaving my mother completely bewildered and with a farm to run. I laid aside my white collar, remodeled my father's overalls to knee britches and returned to the soil, just too darn sober.

★ ★ ★

About the Author

Rosabel Parker Meashaw is a long-time member of SLCHA and very interested in the history of the Parishville area. She adds that she still has the old grand piano from the Temperance Hall which she would gladly give to anyone "for the taking": "We would call him (them) blessed."



Edward Badlam: Inventor of Note

by John A. Baule and
Mary Ruth Beaman

The last half of the nineteenth century was an Age of Invention. The North Country had its share of talented individuals who designed and patented many devices, sometimes curious, sometimes very practical. In a time when an individual could still compete with companies larger than his own, Edward Badlam of Potsdam and Ogdensburg manufactured and sold pianofortes and sundry other devices, musical and otherwise.

Baldwin and Steinway are two well known piano brand names in the mid-twentieth century; and it is probable that even the most unmusical reader is familiar with these companies. During the nineteenth century, however, there were literally hundreds of piano manufacturers, many of whom retailed their products only in a very small area. St. Lawrence County can boast of at least one such company that was owned and operated by a unique musical entrepreneur. Edward Badlam, Jr., a resident of Potsdam and Ogdensburg during most of his life, was a native Vermonter who first came to this county in 1841. He not only built and sold pianos in this area, but also drew upon his imagination to invent and patent several products. Thus, his life and career deserves more than passing mention.

Edward Badlam was a sixth generation member of a New England family who had previously exhibited woodworking and musical interests—both of which were to be important to Edward Badlam's life work. Edward's paternal grandfather, Ezra, and Ezra's brother Stephen Badlam—both Revolutionary War veterans—were also both cabinetmakers. Stephen Badlam, in fact, is well documented as the maker of the noted



Edward and Adaline Badlam and granddaughter Jennie, who died at the age of three in 1871. (Photo courtesy of Mary Ruth Beaman)

Garvan chest at Yale University as well as other pieces of fine Federal furniture. Ezra's son, Edward Badlam, Sr., was probably in the woodworking industry as well. This is somewhat unclear, but he owned insufficient land for farming and the 1820 and 1840 censuses both show him to be in manufacturing. Since his father Ezra and uncle Stephen were cabinetmakers, and since his son Edward is now known to have made pianos with handmade wooden cases, woodworking in some form appears to have been the most likely vocation. Furthermore, references to a musical tradition

are similar. Edward Badlam's own uncle William Badlam of Chester, Vermont, willed a piano to his daughter Mary Ann, and, more important, the earliest American composer of some significance was William Billings, who was related to the first Mrs. Stephen (Elizabeth Billings) Badlam, the great great grandmother of Edward Badlam, Jr. Billings was active in the Boston area during the second half of the eighteenth century, and the resulting musical activities surely must have involved members of the Badlam family, who lived near Boston at that time.

Even more indicative of a musical interest is the fact that Edward, himself, married a woman with musical accomplishments. Adaline Badlam taught in the Department of Music at the Ogdensburg Academy during the early 1850's.

Consequently, the Badlam family traditionally was at least familiar with woodworking and music. Such skills could easily be combined in the manufacture of the piano, which requires a wooden case and musical stringing and adjustments. It was a combination that must have been attractive to Edward Badlam, for he chose to make piano manufacturing a life-long career.

The son of Edward Badlam, Sr., and Mary Graham Badlam, Edward was born in Chester, Vermont, on February 21, 1809. Nothing is known of his childhood but perhaps because paternal relatives remained in the Boston, Dorchester, and Dedham areas, Edward

chose to move to Boston about 1830 after leaving his parent's Vermont home. He spent the early 1830's in Boston, where he trained in the art of piano making at one of the half dozen Boston firms then in existence. About 1833 he began the manufacture of pianos, then called pianofortes. This fact is established by an 1845 Ogdensburg newspaper advertisement that stated he "obtained his knowledge of the business in Boston and was constantly in the manufacture of pianos for 12 years." It is not clear in what location he began his business, but it is likely that he had returned to Chester by 1835. There on September 26, 1836, he married Adaline L. Lowell, a New Hampshire native but raised in Chester by an uncle. Six children, four boys and two girls, were eventually born to this marriage.

Following the marriage, Edward and Adaline moved to Woodstock, Vermont,

where on June 27, 1837, Badlam entered into partnership with Ezra Steele to operate a "pianoforte manufactory." Steele had a somewhat similar background to Badlam. He had been apprenticed to a Woodstock cabinetmaker while quite young, and in the early 1830's also went to Boston to learn the pianoforte building skill. In 1836 Steele had returned to Woodstock and opened a pianoforte factory in partnership with Henry Lawrence. It was following Lawrence's retirement that Badlam, who easily may have met Steele during the Boston years, became associated with the firm. The partnership of Badlam and Steele manufactured pianos until 1841 when, for an unknown reason, Steele returned to Boston.

Badlam then apparently moved west to Potsdam and began his St. Lawrence County career. This probably occurred immediately in 1841. His second son George was born in September 1841 in Woodstock and records made when Edward bought the Chester family homestead from his father on December 24, 1841, list his home as Chester. However, a rectangular piano, now in the collection of the Potsdam Public Museum, bears the nameplate "E. Badlam/Potsdam 1841," and thereby indicates that Badlam was established in St. Lawrence County in 1841.

During his first years in Potsdam, he entered into another partnership. This was with another Vermonter, Benjamin Batchelder, and resulted in a furniture manufacturing business that only produced pianofortes as one of a number of products. The pianos, however, evidently remained Badlam's chief interest, for it was at this time that he invented a noteworthy piano attachment. On October 25, 1845, he became one of the first Americans to receive a patent (#4241) for a swell or third pedal to the pianoforte. This improvement, the subject of both prior and later adaptations, was used to govern loudness in the playing of the piano. In the patent application, Badlam himself described the invention:

"... The combining of the swell with the pianoforte by means of a covering over the strings and having shutters in said covering as above described, so as to confine the sound and with the use of the pedal, as above described, the shutters in said board are made to open and shut gradual or quick at the pleasure of the player, and can produce the crescendo and diminuendo tone or swell in the piano-forte, as above described, and by opening and shutting the shutters quick the player can produce the explosive and pressure tones . . . by the use of the pedal."

Even with this new patent and the advertisements promoting its superior performance, business with Batchelder in Potsdam evidently was not entirely



PIANO FORTE MANUFACTORY,
AT POTSDAM.

EDWARD BADLAM, Jr. would inform the citizens of this county, that he has established a **PIANO FORTE MANUFACTORY**, at Potsdam, and will keep on hand a superior assortment of **PIANO FORTES**, constructed with the **HARP** or **SOFT PEDAL**, which will be offered at prices lower than can be obtained at Boston or New York, and which he will warrant to be of the best quality. Persons wishing to purchase will find it an object to call and examine, before sending to the city.

N. B. Piano Fortes tuned on the most reasonable terms.

July, 1843. 33-6m

Advertisement for Badlam's pianoforte manufacturing establishment in Potsdam as it appeared in St. Lawrence Republican, Ogdensburg, 1843. (Courtesy Ogdensburg Public Library, Microfilm Division)

satisfactory. Following the death in Chester, Vermont, of his father in 1845 and the subsequent sale of the Vermont property, Badlam moved to Ogdensburg in 1846 and effectively dissolved the partnership with Batchelder. Upon his arrival in Ogdensburg he either bought or built a frame business block, soon to be known as Badlam's Block, at the corner of Ford and Caroline Streets. This location is now occupied by the offices of Niagara Mohawk Power Corporation. He was to spend the remainder of life in Ogdensburg, where he derived his livelihood from the manufacture of pianos and the operation of a retail music store. During the years from 1846 to 1868, his prosperity and prominence grew as made evident by his ability to continually purchase various real estate holdings, including his own home at 8 Pickering Street, throughout the City of Ogdensburg. Toward the end of this period, the 1865 New York State Census gives a revealing summary of his business activities. Edward Badlam was listed as a pianoforte maker with a capital of \$2,500 and as the owner of 2,000 feet of lumber valued at \$40 and used as raw materials. Also, Badlam produced annually eight pianos valued at \$2,200 (\$275 each), and had one employee to whom he paid \$30 a month.

This census account, however, does not tell the whole story, for Badlam not only built pianofortes but he also operated a full-service music store. He retailed pianos and organs made by other firms including the Arlington Piano Company of Leominster, Massachusetts, and the Birmingham Organ Company of New Haven, Connecticut. Furthermore, the store sold sheet music and music books, took in old pianos for new, and offered piano repair and tuning services.

Thus, by all indications Badlam was successful in his business endeavors, but he also found the time to indulge in the tinkering and inventive abilities that earlier resulted in the pianoforte pedal patent. In fact, even prior to his arrival in St. Lawrence County, he was awarded a patent in Chester, Vermont, on September 18, 1835, for a "box-setter for boring in hubs". During his prosperous years in Ogdensburg, such activity continued. Two more patents were awarded in the 1860's: #29,745 on August 28, 1860, for a seeding machine or grain drill which was promoted in the local newspaper as a combination of the transverse harrow, the seed sower, and the roller; and #32,551 on June 18, 1861 for another type of seeding harrow. He also is said to have invented an early mowing machine, the patent for which was pre-empted by one of his employees; and to have corresponded with his first cousin Alexander Badlam, also an inven-

tor, for the purpose of financing and marketing one of the above patented inventions. These latter plans are not known to have materialized.

By the mid 1860's Edward Badlam was at the peak of his career, but his prosperity was not destined to last. On or about March 3, 1868, the wooden Badlam Business Block was totally destroyed by fire. Cold weather, the inadequacy of the water pumpers, and too short hose lengths combined to prevent the firemen from containing the blaze. Badlam's business, including six pianofortes and his tools, was burned as were the establishments of a grocer, a harness-maker, a flour and feed retailer, the office of the Superintendent of the Poor, nearby barns, and several residences. Badlam's losses were estimated at \$8,000 of which only \$1,000 was covered by insurance.

This was a severe blow, but within two weeks Badlam had announced his intention to rebuild the entire block in brick. By September 1868, the new block was occupied and a new Badlam Music Store was back in business—offering the same services as before the fire. That same month Badlam was advertising that his musical instruments could be viewed at a special display at the St. Lawrence County Agricultural Society Fair in

Canton.

Thus, the fire appeared to be only a temporary setback, but it soon became apparent that Badlam could not reestablish his business quickly enough. To rebuild the block after so great an uninsured loss forced Badlam to mortgage not only the new building but also a great part of his other modest real estate holdings in the City of Ogdensburg. By early 1869 many creditors had begun to foreclose on him, and essentially halted his musical business career and the building of pianos. The 1869 Ogdensburg City Directory does identify Badlam as a music dealer but the business was conducted only at his home on Pickering Street.

By 1872 his son Charles H. Badlam had completely taken over the business, which he operated with much less success and integrity until 1895. Edward himself continued to be plagued by financial difficulties, and also in 1872 another son, George, bought some of his father's Ogdensburg real estate. Ten years later, in 1882, a referee was appointed to dispose of the remaining property—presumably to satisfy debts still traceable to the 1868 fire.

Edward Badlam was thus denied further business opportunities and rewards, but nevertheless his last few



Piano tuning tools used by Frank Badlam of Ogdensburg, son of Edward. (Photo by author, courtesy of Mr. and Mrs. Lowell McKee, Russell)



*Pianoforte) attributed to manufacture of Edward Badlam. Collection of Potsdam Public Museum.
(Photo courtesy of author)*

years were productive. Patent #245,044 was issued to him for a spoke socket on August 2, 1881, and assigned to his wife Adaline and a D.E. Southwick. On December 19, 1882, patent #269,373 was given to Badlam and Southwick for a vehicle wheel. Also, family sources reveal that he invented a rail car coupling that was never patented, and that he spent many hours carving rail car models.

Edward Badlam, Jr., died on December 19, 1894—his pianoforte manufacturing fame forgotten. Nevertheless, his career in the building and retailing of musical instruments does merit a place in St. Lawrence County history. County residents can justly take pride in the piano third pedal invention, and his many other creations, for in this way, he certainly contributed to the growth and development of St. Lawrence County.

★ ★ ★

About the Authors

John A. Baule is the Director of the SLCHA and a frequent contributor to *The Quarterly*. Mary Ruth Beaman is a tireless, careful researcher who provided voluminous research materials for this (and many other) articles.



*Name plate on above pianoforte). Collection of Potsdam Public Museum.
(Photo courtesy of author)*

Another Great Labor Saving Invention

Mr. Edward Badlam of Ogdensburgh, N.Y., has just received notice that a patent has been granted him, by the Commissioner of Patents, for a new and important labor saving machine, designated by him, as the Transverse Harrow, Seed Sower and Roller, combined. This machine, a model of which we have examined with a good deal of interest, combines all the utility in one machine, of the Harrow, Sower and Roller. Of course, the machine will be worked by horse power, in the same manner as the mowers and reapers. It is so arranged that a part of the harrow precedes the sower and a part follows it, or rather the sower is placed in that position to the harrow, that the seed is sown after the ground is prepared and is then harrowed in. The roller follows and completes the work, leaving the field in a most desirable condition for the reaper in the ensuing harvest, and producing a smooth level surface.

The harrow teeth have two movements, one forward and the other transverse . . . The forward is that which the machine makes in its progress, and the other is communicated by the roller . . . This latter is most beautiful and complete, and cutting the plow furrow cross-wise prepares the ground admirably for the reception of the seed. The sower is so contrived that any given quantity of seed can be sown to the acre, whether it be a peck or any large amount. With this machine a field of grain will be sown with mathematical precision. The track of the harrow and roller are so marked over a plowed field as to enable the driver to sow as evenly as it is possible to draw a line.

The machine is free from complication. In the process of his invention Mr. Badlam repeatedly returned to the starting point, and not until it had been reduced to the utmost simplicity did he apply for a patent. It is unnecessary to say that no trouble was found in obtaining a patent, for nothing like it ever before found its way to the Patent Office.

Every practical farmer will at once perceive the utility and value of this machine, as what now requires the ground to be traveled over three or four times, can by the use of this invention be performed by a single trip. Mr. B thinks the machine can be made and retailed for twenty-five percent less than is now charged for the mowers. He intends to commence the manufacture of them at once, and designs having one

on exhibition at our County Fairs the present fall. We have no doubt this will prove one of the most valuable of inventions, and associate Mr. Badlam's name

along with McCormick's, Morse's and Fulton's.

(from the *St. Lawrence Republican*, Ogdensburgh, 28 Aug. 1860)

E. BADLAM

Grain-Drill.

No 29,754.

Patented Aug 28, 1860.

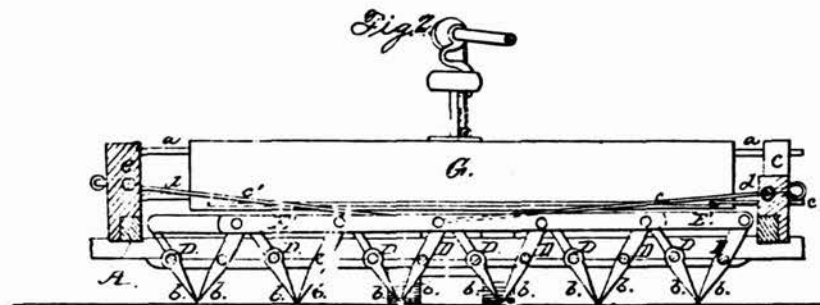
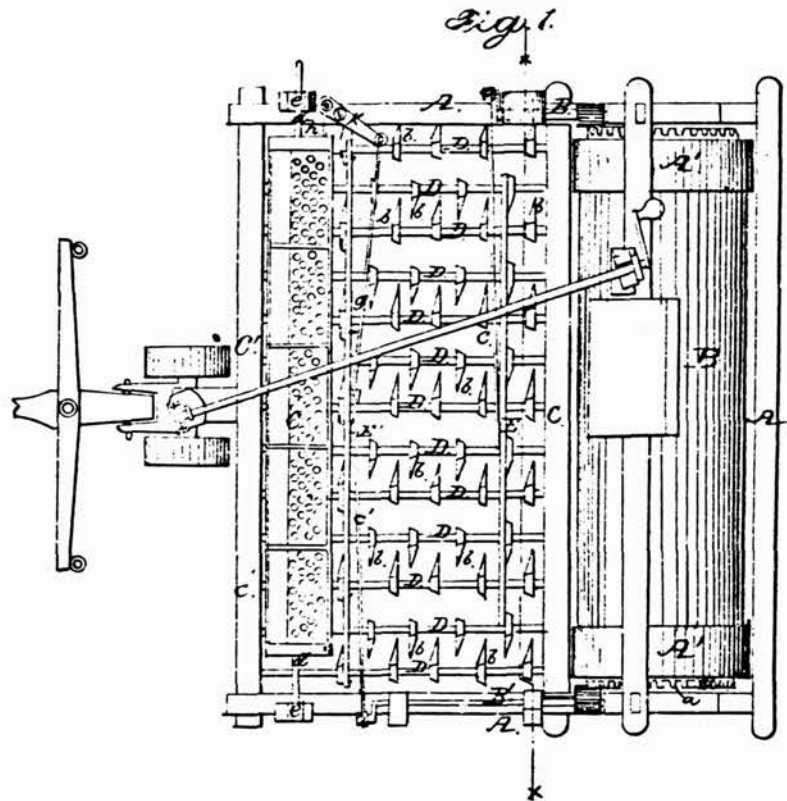

WITNESSES:

W. C. Mumford
R. S. Spencer

INVENTOR:

E. Badlam
Per. Mumford & Co
attorneys

'A Village Today —A City Tomorrow'

by Eleanor and Nina Dumas

It was the first month of the year 1914 when the people of Massena—a small village of 6,000 inhabitants—learned the plans of the Aluminum Company of America for expanding its plant here. The *Massena Press*, a short lived newspaper but an enthusiastic one, announced in bold headlines "A Village Today—A City Tomorrow."

Coincidentally, it was 40 years later (1954) that the Seaway and Power officials revealed their plans and again, Massena was expected to become a city, to be faced with problems of housing and overcrowding in all sectors of the community's life.

The *Massena Press* told readers in the village that the plans of the Aluminum Company for doubling the number of employees, adding over 5,000 people to Massena's population, were revealed at a meeting of the Board of Trade.

The story, in its entirety, appeared as follows:

"The problems incident to the creation of a 'new' Massena, to the building of a city almost overnight, were discussed at a meeting of the Board of Trade held in the Town Hall last evening, the object of which was to face the problem that is before the people of Massena in regard to the housing of the workmen and their families who will come here as soon as the weather conditions permit to be employed by the Aluminum Company of America. It is understood that the working force of the Company will be increased 2,000 men or practically double the force now on the payroll.

"For a number of years the question of finding places for the working men to live has been before the people of Massena. During the last season scores of men were employed here who were unable to bring their families to Massena and a good many of them found it difficult to find homes here for themselves. The increased number of men this year will make the problem even more complex and it was to discuss these conditions that the meeting last night was called.

"For reasons of their own, the people of Massena have been slow to take up the idea of building houses for rent. The company built 105 houses a number of

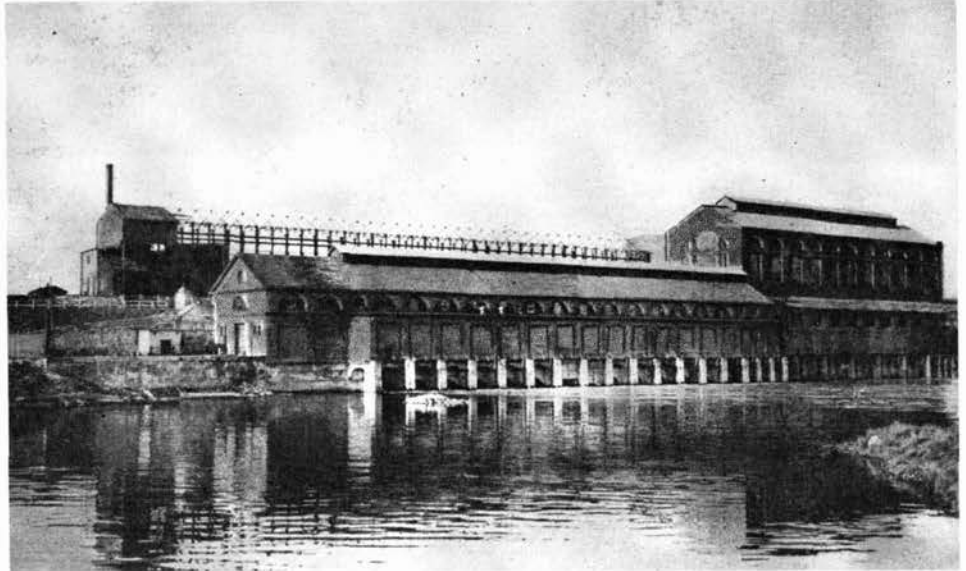

Postcard view of early aluminum plant in Massena. (Courtesy of the History Center Archives)

years ago and there are, of course, a good many houses which are owned by our citizens, but there has been a good deal of indifference along this line on the part of the people who could do this work. If they can be shown that it will be a paying investment there will be plenty of capital to be brought forward for this purpose.

"Mr. (Philip H.) Falter, the new superintendent of the big Aluminum plant, took the people of Massena into his confidence, in his address to the members of the Board of Trade. He explained the lack of housing for the thousand new men who would soon be in town for construction work and who would be followed by another thousand men who would be permanently employed, men with families, who would make Massena their home, thus adding to the permanent population of nearly 6,000 people. There are no housing accommodations for this large population and the company itself did not desire to build the necessary houses on account of the prejudice which exists against living in company-owned homes. The town must provide houses, said Mr. Falter, but his company will cooperate and give any possible aid. It will even cooperate in the matter of raising rents to a point which will give capital a fair income on the investment, even though such a policy should cause some employees to leave. He recognized that those providing the homes must have a fair return on their investments.

"A committee of five was appointed to take the matter up and confer with others, with a view to formulating some solution to the problem which confronts the village. It was announced that outside capital was available if the citizens of Massena do not rise to the occasion and provide homes for the

increasing population.

"A letter was read from A.V. Davis, president of the company, who stated that by April, 1915, the plant would be using all the power developed at Cedar Rapids, which will be double the present power in use at the present works. Dredging of the Grasse River will have been completed by 1915. Mr. Davis also emphasized the necessity of providing for the great increase in the population of the village which will follow.

"H.H. Warner (Warren), the originator of the power plan, N.H. Flaherty and A.J. Hanmer also made addresses. The shirt factory people failed to appear but a committee was appointed to confer with them later.

"Another committee composed of A.J. Hanmer, J.P. Dishaw, G.P. Matthews, H.N. Hall and E.C. (E.B.) Crosby, was appointed to arrange for a dinner to be given in the near future, at which Mr. Davis, Mr. Falter and Mr. Stroughton will be the guests of honor. It is hoped that at this dinner further progress may be made in the matter for development of plans by which Massena may be able to keep up with its own for at present it is in the position of a village growing into a city overnight, an unusual experience for New York State towns.

"But while there are problems to be solved, Massena is not sorry that they are up for solution; she is congratulating herself on the great good fortune which is coming to her and looks forward to a long period of great prosperity."

★ ★ ★

About the Author

Eleanor Dumas is a frequent writer about topics of historical interest about Massena. Nina Dumas provided valuable research items for the article.

FAMILY AND PHOTOGRAPHIC RELATIONSHIP RECORD



LOVE AND

<p>Name Thomas Smith Date Aug 25th 1825 Place Northampton, England</p>	<p>Name Martha Smith Date May 10th 1830 Place London, England</p>
<p>Married to Martha Smith Chilmark Dec 21st 1852 Place London, England</p>	<p>Married to Thomas Smith Chilmark Dec 21st 1852 Place London, England</p>
<p>Alay at St. Lawrence Date 1854 Place USA April 29</p>	<p>Alay at St. Lawrence Date 1854 Place USA April 29</p>



TRUST









<p>Name Emily S. Smith Date September 29th 1848 Place Chelsea, England City of London, England Married to Georham C. Leonard Chilmark Dec 1868 Place St. Lawrence, N.Y. Date USA April 66</p>	<p>Name Alfred Smith Date July 1850 Place Hilton, N.Y. Married to May Miller St. Lawrence Dec 21st 1873 Place St. Lawrence, N.Y. Date USA April 65</p>	<p>Name Edward Smith Date Aug 5 1852 Place Chilmark, N.Y. Married to Sally H. Wood Chilmark Dec 21st 1874 Place St. Lawrence, N.Y. Date USA April 78</p>	<p>Name Lawrence Smith Date 1854 Place St. Lawrence, N.Y. Married to Sally H. Wood Chilmark Dec 21st 1874 Place St. Lawrence, N.Y. Date USA April 78</p>	<p>Name James Smith Date May 22-1856 Place Perman, St. Lawrence, N.Y. Married to Sacada M. Gates Perman March 19 Place St. Lawrence, N.Y. Date USA April 78</p>	<p>Name Thomas Smith Date October 1858 Place St. Lawrence, N.Y. Married to Kathy H. Apple St. Lawrence Dec 21st 1878 Place St. Lawrence, N.Y. Date USA April 78</p>
---	--	--	--	--	---





<p>Name Anna Smith Date Dec 18th 1860 Place St. Lawrence, N.Y. Married to Richard Morrow Perman Dec 21st 1881 Place St. Lawrence, N.Y. Date USA April 81</p>	<p>Name Anna Smith Date March 1865 Place St. Lawrence, N.Y. Married to Richard Morrow Perman Dec 21st 1881 Place St. Lawrence, N.Y. Date USA April 76</p>	<p>Name Anna Smith Date 1871 Place St. Lawrence, N.Y. Married to Richard Morrow Perman Dec 21st 1881 Place St. Lawrence, N.Y. Date USA April 76</p>	<p>Name Anna Smith Date 1871 Place St. Lawrence, N.Y. Married to Richard Morrow Perman Dec 21st 1881 Place St. Lawrence, N.Y. Date USA April 76</p>	<p>Name Anna Smith Date 1877 Place St. Lawrence, N.Y. Married to Richard Morrow Perman Dec 21st 1881 Place St. Lawrence, N.Y. Date USA April 76</p>	<p>Name Anna Smith Date 1877 Place St. Lawrence, N.Y. Married to Richard Morrow Perman Dec 21st 1881 Place St. Lawrence, N.Y. Date USA April 76</p>
---	---	---	---	---	---

A page from a late nineteenth century family photograph album illustrating the genealogy of Thomas and Martha Smith, subjects and authors of this letter. Thomas and Martha Smith appear at the top of this family record. (Courtesy of Reginald and Betty Smith)

“... a good country for a poor man to come with a family”: the Smith Family Letter

Edited by Varick A. Chittenden

In these days of rapid transportation and communication, when even many average citizens get to travel abroad in their lifetimes, it is difficult to imagine the great fear our ancestors must have had in uprooting themselves from familiar surroundings in the Old World and sailing away to America, perhaps never to see loved ones again. It is difficult to comprehend the sense of homesickness for familiar people and things while being confronted with so many new ones. This very long letter, written from a relatively settled town of Waddington in 1851 back to the family home in Great Britain, is an invaluable record of these people's feelings but an even more valuable source of information and observations about early life in northern New York. It is a fascinating interpretation of many experiences which we take for granted, based on our training in American history in this country. Such a range that Martha covers in her letter: from building fences to working with oxen, from the presence of wooden floors to the absence of window taxes, from the novelty of a sleigh and a home wedding to the serious explanation of wages and the lack of work. It is a real study in culture shock and an acceptance of new ways. For us there is a need to appreciate the compulsion to explain new experiences in familiar terms—like the use of British currency and weights—and the great sense of excitement our forebears had for simple little adventures. We very much appreciate the willingness of Reginald Smith of Canton, direct descendant of Thomas and Martha, to share this great family document with us. Incidentally, Mary Smallman points out that the letter was sent in 1851, marked paid, and sent back to America later for three cents. Comparable postage now would be 62¢ per ounce!—VAC

Waddington, N.Y., Nov. 1851

Dear Father and Mother,

This comes with our kind love to you, hoping to find you all well, as I am happy to say this leaves us at this time, thank God for it. I am afraid you begin to think us neglecting in not writing sooner, but we thought we had better wait until we could tell you how we like the country and tell you something about it. I am happy to tell you we like the country very well and this is considered a very healthy part. Waddington is a village on the bank of the St. Lawrence River but we don't live in the village. It is about as far from the village as from Hilton to the five arch bridge but we cannot say we like our neighbors quite so well for they are almost all French but there is one who sends us a quart of new milk in the morning and we have had plenty of milk all summer for most of our neighbors keep a cow for it costs them nothing all summer for they go into the woods where they like to feed and butter has never been more than 6 pence a lb. and eggs 3/2 per dozen. I must tell you how strange everything looked to us when we first came. The fences are made in and out in that way to divide the fields. They are pieces rent of trees and then they are laid on each other three or four pieces high and the fields looked as strange for they cut the trees about a yard and a half from the ground and leave the stumps to rot and then they drag them up with oxen. It is very common to see oxen draw wagons instead of horses but the wagons are not built as they are in England.

They just have two pair of wheels and two deal boards along the sides and about three at the bottom, so there is not much work in making them. They have things they call buggies that they ride in. They have two pairs of wheels and a bottom and one deal board, and a seat across them. They have no fine carriages about these parts, so you may tell John and Jerry Warren it will be no use them

thinking of coming, for they have no livery servants, but we should like them to come for this is certainly a far better country than England.

Now dear Mother, I must tell you their way of living. In the first place they are very early risers. Most of them have breakfast by six o'clock in the summer as the men have breakfast before they go and come home at 12 for

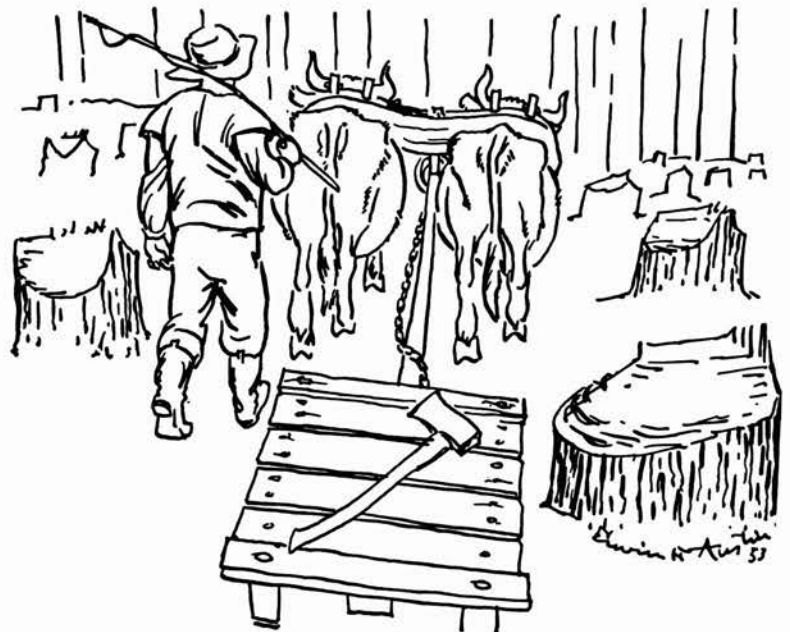

*A pioneer with a yoke of oxen in a cleared field littered with tree stumps. (Reprinted from *The Golden Age of Homespun*, courtesy the New York State Historical Association)*

dinner. They live quite different here than they do at home. They always have meat and potatoes, bread and butter, cakes and pies for breakfast and dinner and most people have pies and cakes on the table for what they call supper, that is generally about six in the evening. They have no late supper here but we always have tea three times a day. I must say I like the way of living much better than yours now I've got used to it and so does Tom for we have a great many more nice things here than we could at home.

Butter and eggs are so much cheaper. They each have an oven and bake their own bread. We make our own and I have some nice candle moulds so I make my own candles and I shall make my own soap. I can assure you we get quite Yankee as that is what the people are called here. Dear Mother we have got a nice stove, the price was 3 pounds 4 shilling, but we got it easy for they took Tom's watch in exchange for it, for it is well we did not sell it at home, as we were not offered only 50 shilling for it. I think you would like them as I can have 2 dinner pots and a teakettle on it at one time and I can bake 2 loaves of bread at once and they are handy for ironing. The irons heat so clean. We are obliged to iron all as we have no mangles here. We use all flat irons.

I am happy to tell you we have got a nice pig. We bought it in August and gave 9 shillings. We think of keeping it 'till New Years and then we shall salt it down in our own tub so then we shall have plenty of pork. We expect it will weigh 12 stones by that time. We feed it on Indian corn and that is 2 shilling per bushel and Tom says they do as well on a bushel of that as on a bushel of your peas. We can get a quarter of lamb to weigh from 8-10 pounds for 1 shilling 9, and beef is 2/3 per pound, but they don't fat the meat up so well here but I suppose they do in larger towns. Wheat is now 3 shillings per bushel and at the flour mill we can get 50 pounds for 4 shillings.

Dear Mother I wish you could see what a nice little comfortable house we live in. It is painted white and green shutters to it and it is so warm that if the weather is ever so cold we shall not be cold in the house. It has 6 large sash windows in it so we have plenty of light and there is no window taxes here. Our floors are all painted so they are not much trouble to clean. They are all boarded floors here and I can clean all my floors here almost as quick as I could any one in Hilton and the rooms are built so much higher here, makes the houses look so much better.

Dear Mother I will tell you what Tom said to me the other day. He said he would not come back to live in Hilton if they would give him the house we lived in and the church close with it. I wish

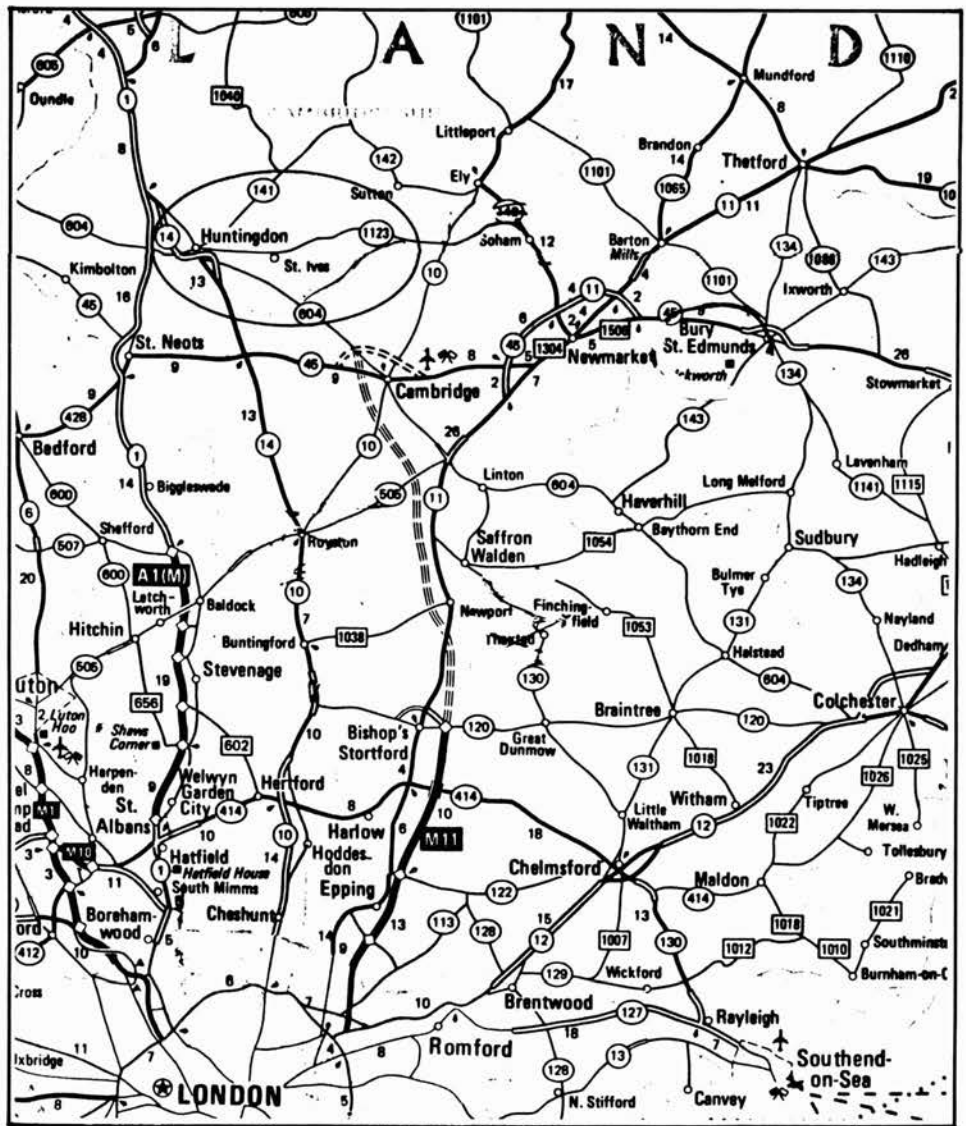

Map of eastern England, Cambridgeshire, and Huntingdon and St. Ives, the native villages of the Smiths, where this letter was sent. (Courtesy of Mary H. Smallman)

you was all here and I would certainly wish a great many to come, if it was not for crossing the ocean, but I hope Susan will come when John Warren comes with his new wife and we often say to each other how well Hurst might do if he was here for carpenters never get less than 6 S per day and they can always get plenty to do. You might tell him to come and never mind how many children he has for he can give them all trades here free of expense and we can take them all in for we have plenty of room and I should very much like my dear brother William to come. I am sure he might do a great deal better here than he can in England.

I will tell you what Tom did. The first days work was planting Indian corn and after that he planted his own garden for we were here quite time enough to plant anything. We have had Indian corn, potatoes, cabbage, turnips, beets, pumpkins, cucumbers, beans, peas, and onions but we have had rather a wet

summer so that the potatoes nor the corn are not so good as they would have been but we have plenty for our own use. We eat a great many more potatoes here than we would at home, having them for breakfast.

They say in England there is no taxes here but there is one and that is road tax and every man has to work a day and a half. Tom was in time to work his own and then he worked seven days more but the time on the road is only from 8 'til 5 and they get a half crown a day. After that he got several days more for which he always get 3 s a day or else shop goods equal to 3 s. Then he went to hay work three miles from the village. He went on the 8 of July and was there 3 weeks, he had 3 s per day and his board.

Dear Mother, I must tell you that there is but very little beer drank here and Tom wishes me to tell you how much he misses it. When he was at hay work, he thought the time long from 6 in the morning til 12 noon, but there is liquor

sold here very cheap indeed but I am happy to tell you Tom has never been that worse for drink since we have been here. But I must tell you that it is quite common here to see the women smoking and in the summer when the weather is hot a great many of them go barefooted and the women never wear stays here. I did not in the summer but I was glad to put them on in the fall.

We were very much favored with the weather this summer. It was not much hotter here than it is in England, and we have had one fall of snow this fall, but it soon melted again. Sometimes the snow comes in Oct. and don't go off until March or April.

Tom used to come home once a week when he was at hay work, after he had been the three weeks he went 10 days for another man and then he rested a week in which time he built his pig sty and got his wood in for we burn nothing but wood here and the way we buy wood is by what they call a cord and a cord is 8 foot long and 4 foot high and the wood is 4 foot long, and they stack it up as I have told you and that is 4 s and it lasts three weeks or a month. But we don't expect it will last more than 3 weeks this winter. Our stove takes wood 2 foot long.

Dear Mother it is much easier to have a trade for instead of paying for an apprenticeship as in England they are paid all the time at what ever trade they like and have their board as well and such a boy as Wm. Warren would get as much as 2 s a day at laboring work. I think I would advise Aunt Warren not to object to John coming to America any longer for I am sure 3 s a day is better than 16 pence and then everything else is so much cheaper according. Wearing

apparel is rather dear here but it is not in large towns. Furs are cheaper here than in England.

We have got 7 bu. of apples, we gave 1 s/per bu. for them and the way we do here to keep them is to peel them and cut them into quarters and string them on thread and then we hang them on sticks round the stove pipe. We have 4 hooks in our kitchen ceiling to put the sticks in and we let them hang until they are dry and hard as chips and when we want to use them we take as many as we want and put them into a tin pan and wash them as they get dusty with hanging and then we put them in cold water on the stove and they will all swell out again as large as ever. We never have apple dumplings here but we make nice little pies about as large as a plate and very thin and we have nice pumpkins we make into pies. We cut them into slices and some we dry as we do the apples and some we cut into pieces and stew them, and then mix them with eggs, milk and sugar. I can assure you they are very nice.

I do think father would like our way of living. I must tell you the way they do here when they have much needle work to do. They have what they call a bee and prepare a good supper and invite as many as they think proper to come to it and they all go as early as possible after dinner and they all work as hard as they can. They are great hands for fancy quilts, I never saw any joined as they do them here. Some of them are very handsome, and they have what they call a quilting bee and do as I have told you, and they will get almost a quilt done in the afternoon. The men do the same when they have anything to do they

want done in a hurry. If it is with wagons a lot of them will go and help them with theirs so I think you will say it is a good way. At any rate it is a friendly way. The way they do when a poor man takes a bit of land, he cuts the wood down in readiness and then he will have a bee and a lot will go and help him and they will almost build his house in an afternoon, but that is what they call a log house.

The way they build a log house is hew the sides off level and cut pieces out of the ends to make them fit in tight and then they lay the logs on each as loose as they can and then they plaster them in between. They build these kind of house until they can get better. Some never get a better and I would much rather have one of them than the clay houses in England for they make them so much warmer, but ours that we live in is not a log house. It is a good frame house and what they call clapboarded on the outside. I will tell you the way they do the houses here in the winter. They bank them up, that is to put earth all around them almost as high as the windows that is to keep the frost out. Everybody here has a cellar. We have a good well in ours so I don't have far to fetch my water and they all have what they call a shed built at the back joining the house. Some people live in them in the summer and most of them have their stove in them in the summer and they are handy to put the wood in the winter. They have a hole cut in the top to let the stove pipe through.

Now I will tell you what they call some of the things here. What we call prints in England they call calico and what we call calico they call cotton cloth and all kinds of tea things such as cup and saucer they call dishes. What we call dishes in England they call platters and they always use the word fetch for carry, bring or take. And now I think I have told you all I can think of but you may tell Susan she need not mind coming over single for there is some nice young men here. I have a nice room for her and my uncle has got a son, just the thing. He is tall and I think him a nice young man, his name is William. People marry here in their own houses. Dear Mother and Father we have got three places of public worship, one of our Churches and a Presbyterian and a Roman Catholic but there is more goes to the last than both the other two. There is a nice Methodist Chapel begun but they can't finish it for want of money.

This used to be a good village for business but it is not so good as it was but most people live in their own. They have about an acre of land and build a house on it. There is not many farmers here but we don't think of remaining here longer than this winter but we don't know yet where we shall go. We shall

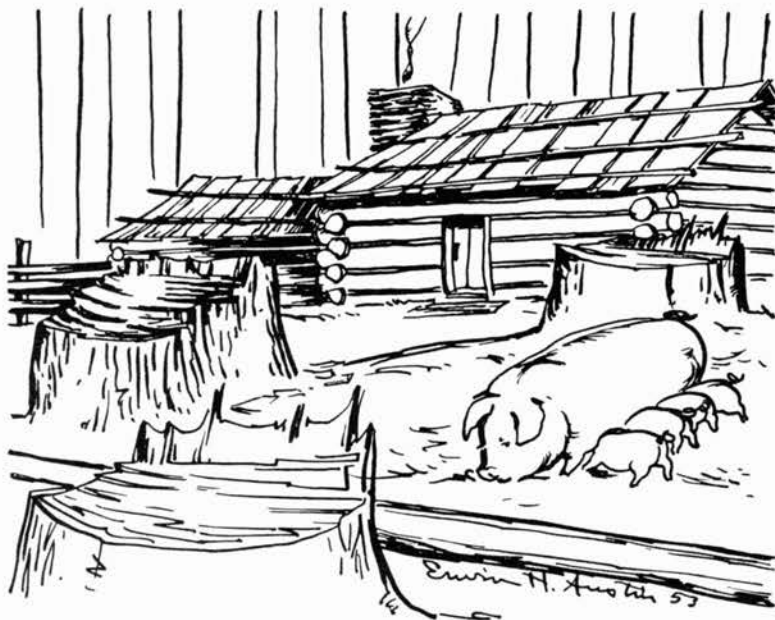

An early log structure such as Martha Smith describes, with sow and litter of pigs in yard. (From *The Golden Age of Homespun*, courtesy of the New York State Historical Association)

write again before we move, if we do move. I don't get much work as I live out of the village and most people make their own but what work I do I am much better paid than I was in England. I get as much for making one dress as I used for 2 at home, but I have not much time for needlework.

I should like you to see the sleighs go now the snow is on the ground. You may tell Hurst if you have much snow there this winter he must make George one. They are made something in the shape of a wash stand. They have pins from the body to the piece that goes along the bottom of each side. They have no wheels but there is a piece goes along the bottom on each side with iron on it so that it slides on the top of the snow and these are turned up in front like a plow slides. They are very good things for the snow for one horse can draw as much as two with a wagon and every horse has a row of little bells around his neck. That is when they go out in the morning early they can't see and they go so still with the sleighs that they would not hear each other without the bells. And now dear Mother I have no more to tell you about America. Will you please tell Aunt Warren, uncle, aunt and cousins all send their kind love to you all? Uncle is about the same, he suffers a great deal with rheumatism but he mostly gets into the village every day if the weather permits. All the rest of the family are quite well. I have nothing in particular to tell you about them. He told me last Sunday he should like to see you. I hope you will give our kind love to my dear sister and brother and tell them we are very happy and comfortable here and we don't wish ourselves back in England again but at the same time we should like to see you all.

Tell James my dear little Emily sends her love to him and send a kiss for you all and asks if you are in England and she says her aunt Susan brought her over the great water. She grows a great girl and is as fat as ever. She talks quite plain now. I must tell you all the children here wear trousers so she wears them. She tells us now about the man cutting her grandfathers knee and this morning she told me her grandfather ate her grandmothers sugar. My dear little Alfred has never been very well since we have been here for he has cut his teeth so fast, he has got 6 single teeth and 2 double ones. He has run alone these 2 months and he has been weaned about the same time as he has run alone, but I hope he will get on this winter. Tom has had his health better here than he had at home. I have bought him some nice flannel shirts and give 1 s 9 p per yard. Flannel is dear here.

Please to give our kind love to William and Jane and kiss the dear children for us and send us word what the last child's

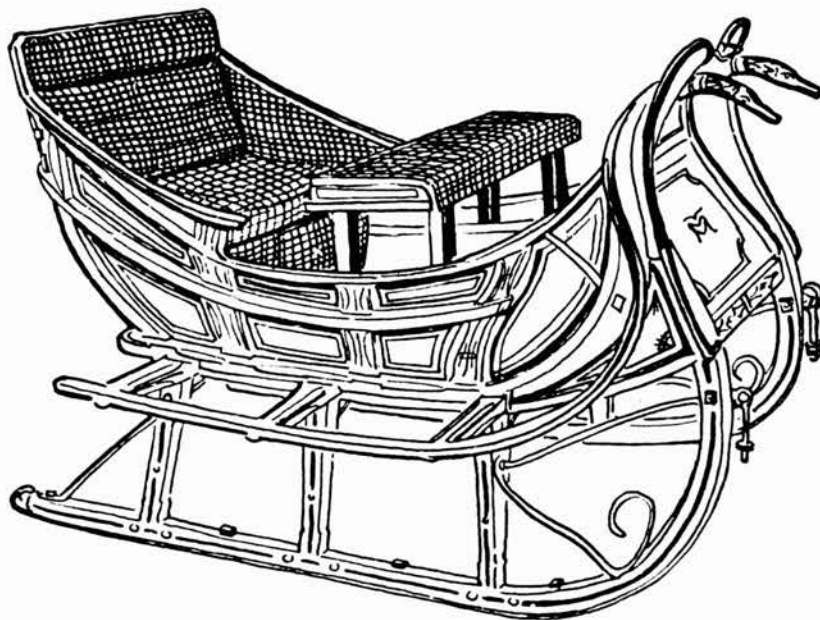

A sleigh, "made something in the shape of a washstand." (From *The Golden Age of Homespun*, courtesy of the New York State Historical Association)

name is and our kind love to father and Susan and we shall expect Susan to come with Hurst in the spring, and then we will go and live in Ogdensburg. That is the place that has got up and flourished within this last 2 or 3 years. There was a thousand carpenters worked there last summer. Give my kind love to William and Susanna and tell Susanna she must not mind crossing the sea, but they must make up their minds to that for please God they have a pretty good passage. It will be over in a month or 5 weeks but I would not advise anyone go on a full diet as the meat is not good you get on board the ship and the money they would pay extra would buy a good many nice things.

Tell Mrs. Garret we often wish we had Mary Ann to keep house as I could get plenty of work if I could go out and girls won't go out under 2 or 3 s per week.

Please give my kind respects to her and all my neighbors and to Mr. and Mrs. Bedford and tell them there is no confectioners in this place but have no doubt they might get a good living here as there is a good deal of candy sold at the stores but it is not made here. Tom says you may tell—that he is not at all disappointed in the country for it is a good country for a poor man to come to with a family. Our landlord has been out on a visit for a month and Tom done 13 days work for him while he was gone and Tom went to draw 1 L 19 s for his work, and when he came out he shook hands with him. That is more than the farmers would do in Hilton. Tell John he must come and buy 100 acres of land and there is parts in Canada and in the west where he could buy a 100 acres for 20 L, and the wood that stands on it will pay for the clearing of it but if you do this you



A full cord of wood, 8' x 4' x 4'. (From *The Golden Age of Homespun*, courtesy of the New York State Historical Association)

will see more mice and squirrels than people. Tom says I am to tell you it is people who go out into the woods 5 or 6 miles from any town and build them up a log house and after awhile it turns out to be a brick house, they are the people who get on in the world.

If John comes he must go in shares with Tom as a great many people in this country, and I must tell you the way they go in shares. The farmer plows it and finds seeds and the laborer plants it and moulds it up and digs them and then they divide them. Potatoes are planted

further apart here than in England they are planted in hills like a mole hill. I hope dear Mother you will be so good as to send this letter to my dear sister and brother and to John and we hope we shall soon hear from you and send us all the news you can. I shall like if my sister would be so good as to send Mrs. Rignals address and ask Mrs. Taylor for John Lavendar's address. And now I must conclude with our kind love to Father and yourself and all friends and believe us to remain your Affectionate Children.

Signed

Thomas and Martha Smith

Please to give our kind love to Uncle, & Aunt & Sally Sharp. If any of our friends should make up their minds to come they had better write to us and we will give them all the information we can. Good-bye and God Bless You All.

This letter to

Thomas Smith
Hilton Near the Church
Near St. Ives,
Huntingdonshire
England

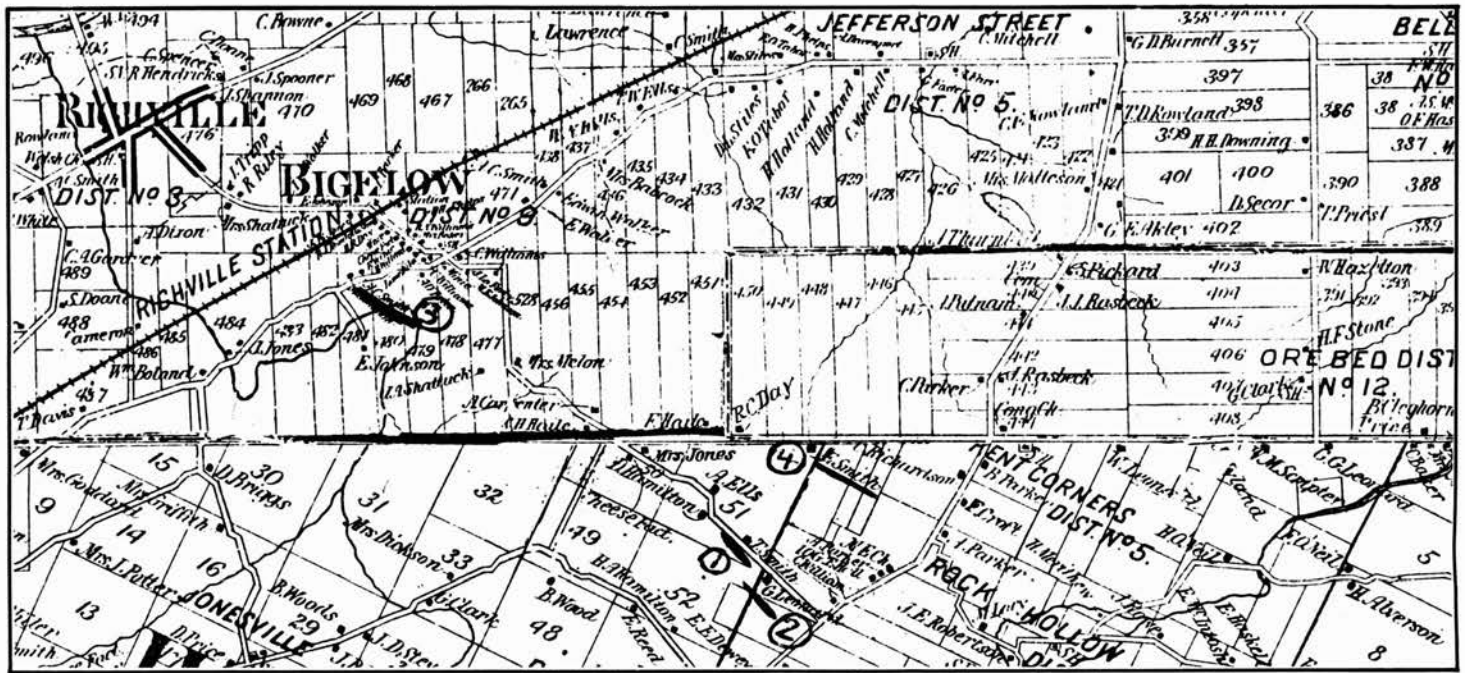

Map of Bigelow area outside of Richville, where Smith Family moved from Waddington. (1) Thomas and Martha Smith home [still standing]; (2) Susan Smith Leonard and Gorham Cross Leonard home; (3) A.C. Smith home; and (4) F. Smith home. (Courtesy of Mary H. Smallman and History Center Archives)

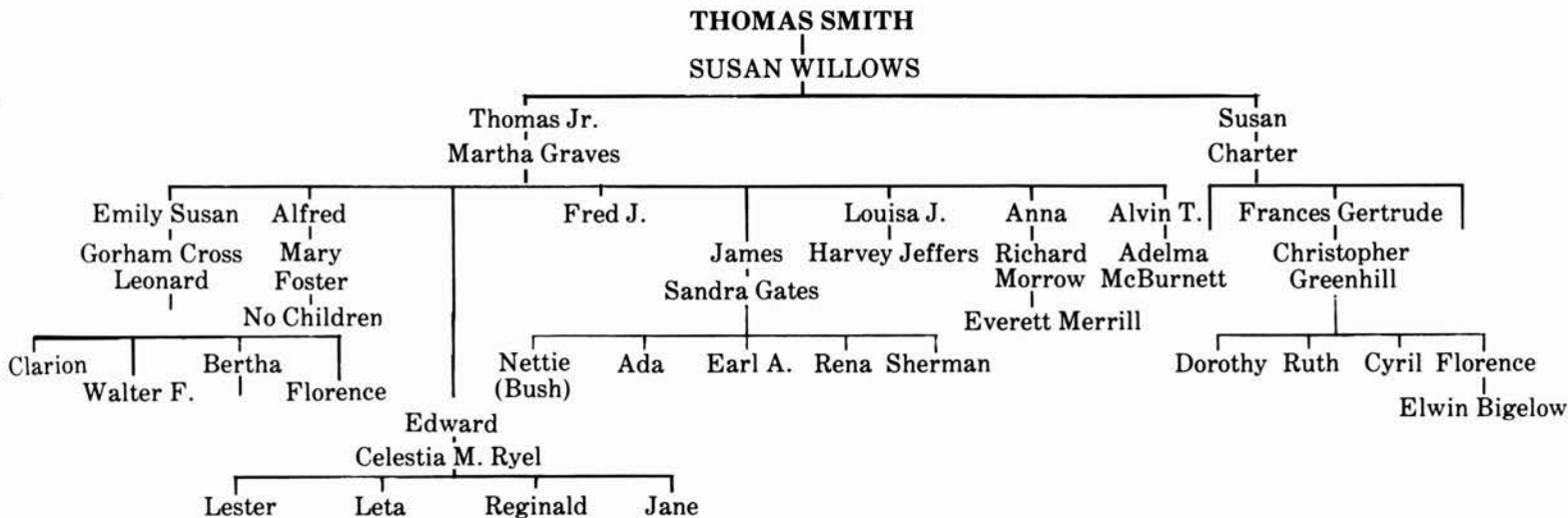

Family tree of Thomas and Susan Willows Smith. (Courtesy of Mary H. Smallman)



Food for the Hungry . . . Drink for the Thirsty . . . Rest for the Weary

A nostalgic postcard album tour of some early hotels and taverns that dotted our county's highways through the years. Many began as stage stops and later became family homes; others, built on a grander scale, served a large and varied public, from lonely travelling salesmen to whirling dancers in formal dress. Although a few still survive, most have sadly become victims of fire, the wrecking ball, or of negligence.



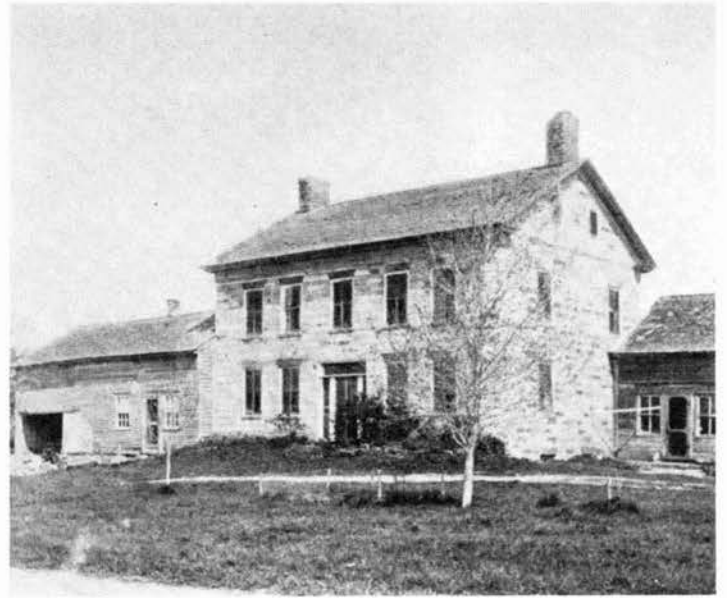

Postcards used in this essay
are from the Collection of the
History Center Archives.





The Hotel Edwards, Edwards, N. Y.

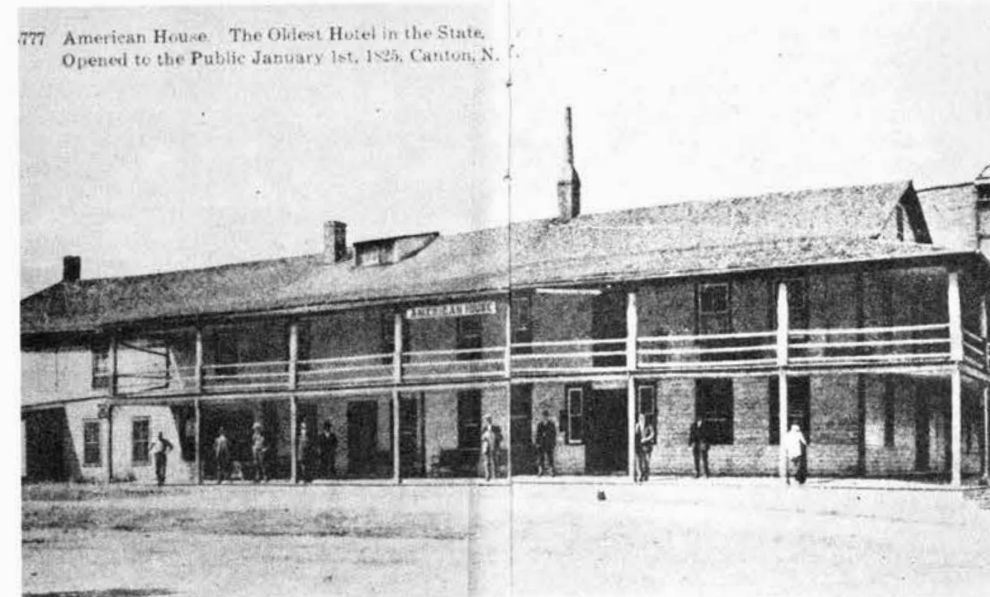
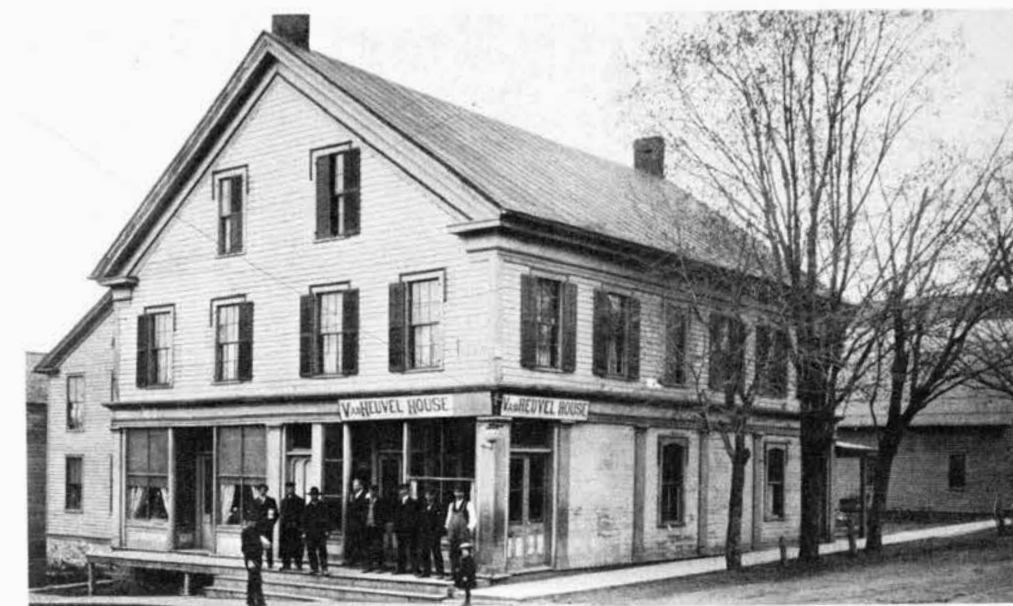
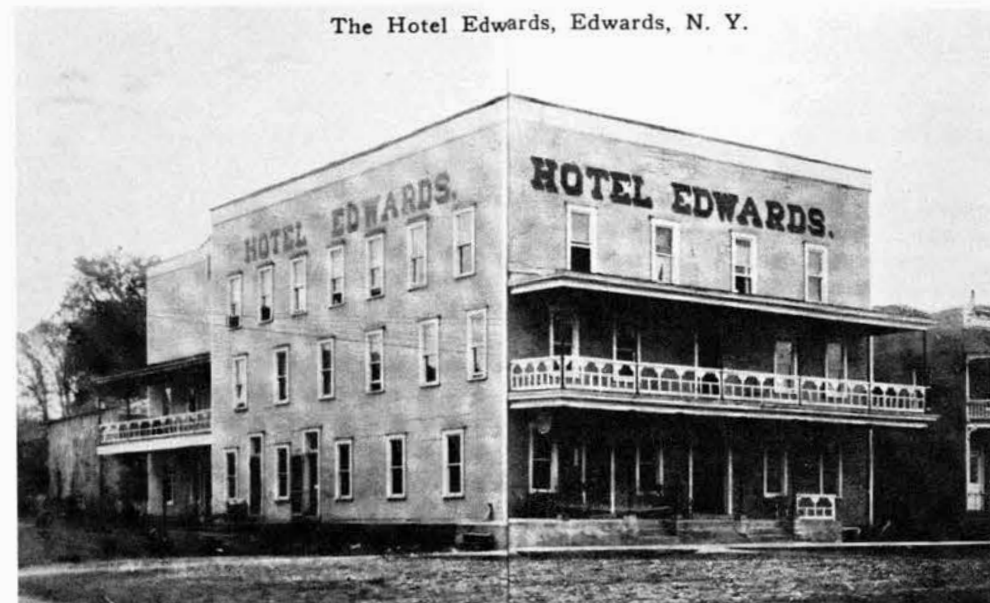

777 American House. The Oldest Hotel in the State. Opened to the Public January 1st, 1825. Canton, N. Y.



The Bridge Built by Three Towns

by Pauline Tedford

In what today would be a certain bureaucratic boondoggle in 1902 proved to be a successful exercise in delicate negotiations and small town cooperation. The result: the Chase Mills bridge over the Grasse River.



Nowadays as we travel the main roads of our county we ride across rivers, accepting without question the convenience of the bridge and the security of its structure. We know the problems of maintenance are being taken care of by the state or the county, and we need feel no concern. In the past this was not the case, and towns were often confronted with construction and maintenance costs that seemed staggering.

Such was the situation in 1902 when a new bridge over the Grasse River at Chase Mills was contemplated. Old town records tell of the resistance made when Madrid and Waddington were ordered to assist Louisville in building the Chase Mills bridge.

On June 12, 1902, Supervisor Whitney of Madrid met with the Waddington Town Board at a special meeting to discuss the order.

The Waddington Town Board, namely, Supervisor Hon. C.S. Plank, Justices Robert Thompson and C.L. Montgomery and Clerk A.B. Shepard, assured Mr. Whitney that Waddington would assist Madrid in any way possible. Madrid had been ordered to share in the bridge expense and in addition had been directed to lay out a highway on the town line between Madrid and Louisville to meet the bridge across the river.

As counsel to aid L.P. Hale, who was attorney for Madrid, the town board appointed Charles Plank, A.B. Shepard and C.L. Montgomery, all lawyers from Waddington. They were to appear before the commissioners appointed by Hon. H. Swift, County Judge of St. Lawrence County.

The minutes make no further mention of the road, so it is evident that that question was ironed out.

But the bridge controversy was not settled by the next March and R.E. Waterman of Ogdensburg was retained to argue the motion on behalf of Waddington before Judge Spencer at Gloversville on March 21. The discussion was carried on to a hearing before the

Referee on June 3 and for this George VanKennen was retained to be assistant counsel to R.E. Waterman. The decision denied Waddington's and Madrid's plea and by April 1904 we find Waddington voting to pay the Referee's fees.

The next question was whether they should appeal from Judge Spencer's decision. This seemed inadvisable and it was decided to meet with the Town Board of Louisville to ascertain terms of building the bridge.

A committee met with the Louisville supervisor, Walter Wilson, and the Highway Commissioner at R.E. Waterman's office on August 29, 1904 and the terms were to be these: Waddington to pay one-third of the expense of the bridge and Louisville to pay the expenses of litigation, amounting to \$475,000.

The bridge expense was an enormous one to incur and to get the sentiment of the taxpayers, a public meeting was held in the town hall. Bert Capser was elected chairman and A.B. Shepard secretary. R.E. Waterman gave the history of the case after Supervisor Plank had presented the question. It was voted by the taxpayers not to appeal but to make settlement, the vote being taken by having those in favor of appeal stand on the south side of the hall and those for settlement on the north side.

At the meeting of the town board which followed the public meeting, the vote of the people was accepted.

A week later the three town boards met in Nowlands Hall at Chase Mills and heard the specifications of the

bridge—340 ft. long, capacity of ten tons on four wheels, to be of steel of three spans, 16 ft. wide; floor of three-inch hemlock or 2½" beech.

At a meeting October 11, 1904 in Creighton's Hall in Chase Mills, Walter Wilson presided and the final order of Judge Spencer was read. Bids were opened by the highway commissioners and the contract for the bridge was let to the United Construction Company of Albany for \$10,000.

The next day the Waddington town board approved the contract. The bridge was built and finally accepted the next year on August 19, 1905.

The Chase Mills bridge is the only one in St. Lawrence County to be built and maintained by three towns.

The bonds issued fifty-five years ago to raise the \$3,300 have long since been retired. The bridge has been taken over, rebuilt and maintained by our county system. Few people now remember the two year struggle and the problems of those three early town boards. As we said at the start of this glance into the past history, we drive over the Chase Mills bridge without a thought for the problems of those three town boards of half a century ago.

★ ★ ★

About the Author

Pauline Tedford is the Town Historian for Waddington and a frequent contributor to *The Quarterly*.

Letters to the Editor

The Wright Corner

by Mary Ruth Beaman



To the Editor:

Both my wife and myself, having been born and raised in Northern New York, are avid readers of *The Quarterly*.

I was particularly interested in the article, in the most recent issue, written by John R. Greene of Syracuse. The genealogy of the Tozer family was nostalgic to say the least. However, the part concerning Arthur Davenport and that of Frank and Celia Lawton touched on facts relating close to my own boyhood in the Evans Mills area.

As a boy I lived with my mother and stepfather, Earl Fleming, on a farm owned by Frank and Celia Lawton. On many occasions I drove a horse and wagon to Evans Mills with grains to be ground at the mill owned by Davenport and Hass.

Mr. Greene's article indicated that Arthur Davenport sold his interest in the mill before it was acquired by Mr. Hass. I knew Arthur Davenport well and the mill was operated under the name of Davenport and Hass. Later Mr. Hass turned his share of the business over to his son Roger Hass who ran the mill with Arthur Davenport remaining in an advisory capacity until his death. From what I know, it would seem that Arthur Davenport did not sell out his interests, or if so, he bought back into the business at a later date. All of this may be quite irrelevant as relating to the Tozer genealogy but it is possible Mr. Greene would like to have this information.

On another subject that may be of interest to you, my wife has pictures of the Old Fuller Sheds in Gouverneur and the first or one of the first cars to be owned by a Gouverneur resident. The car was one of the first Oldsmobiles and was owned by her maternal grandfather Mr. Theodore Storie and shows him and his son Kenneth sitting in the car. My wife is Kathleen Laidlaw, daughter of the late George and Nina Storie Laidlaw, also a cousin of Harold Storie.

We would both like to commend you on the very fine job you do with *The Quarterly*. We read and enjoy each issue cover to cover.

Sincerely,
Clarence and Kathleen Munger
3631 Marian Drive
Trenton, Michigan 48183



The Sheldon Museum, Middlebury, Vt., not only has the cradle that belonged to Silas Wright but also has many original Wright family letters.

For those of you interested in doing extensive research on Gov. Wright, there are 300 letters from him to Azariah Cutting Flagg in the Azariah Cutting Flagg papers in the New York City Public Library.

Poultney Bigelow, author of "Seventy Summers," and art classmate of Frederic Remington at Yale, was born in 1855 to the Hon. John Bigelow, a graduate of Union College. The latter, in 1845, was appointed one of the Inspectors of the State prison at Sing Sing by Gov. Wright.

We have received many letters during the past few years in which people claim, rightly or wrongly, relationship to Gov. Silas Wright. The confusion is understandable to those involved in genealogy. However, back in August 1843, one William S. Wright attempted to benefit financially by representing himself as a brother of the then Senator Wright. Over confident from previous success in this venture he became careless and was caught. In Washington Criminal Court he was tried and the jury found him guilty. (From the Northern Cabinet and Literary Repository)

In August 1834 Silas and Clarissa Wright, with their friends Mr. and Mrs. Minet Jenison, took a trip to Michigan Territory traveling most of the way by water. On the Great Lakes they ran into bad weather and suffered a great deal from seasickness. In Michigan the Senator found himself constantly beleaguered by western politicians. Their excursion carried them fifty miles beyond Detroit and Mr. Wright did not return to Canton until mid September. (from "Silas Wright" by Garraty.)

In the early 1820's Silas Wright was hung and burned in effigy by the village liberty pole on the banks of the Oswegatchie in Ogdensburg because of a misunderstanding over the electoral law vote.

★ ★ ★ ★ ★ ★ ★ ★ ★ ★

Pliny Wright, brother of the Governor, was also a graduate of Middlebury College in 1827. He worked for a year in the office of Col. McKown in Albany. He returned to Canton and for a while worked in the law office of his brother and Silas Baldwin, Jr. He had suffered a nervous breakdown and was hospitalized in Utica for a time, then worked in the hospital until he again returned to Canton and took up farming. When he died in 1890, it was found that he had an estate of over \$15,000.

★ ★ ★ ★ ★ ★ ★ ★ ★ ★

In Feb. 1886 a costume party was held at the home of Mr. Robert Sackrider in Canton. One garment of historical interest was an elegant black dress coat, made for Silas Wright when he was Governor, which was worn by Mr. Murray N. Ralph. The coat showed no sign of wear and probably was never worn by Gov. Wright except at the inauguration of his successor, John Young, and at his own farewell reception on the 1st of January, 1847.

The cost of publications and other operating expenses of the St. Lawrence County Historical Association are partially subsidized by this advertising support.

Barbour's
The Alcoa
Foundation
Mayhews
Wholesale Inc.
The
Barnhart Trust
and other
Friends of
the Association

If your corporation or institution would like to support Association work, a representative will gladly discuss details with you.

Address Correction Requested
Forwarding and Return Postage
Guaranteed
Box 8
Canton, N.Y. 13617

BULK RATE
U.S. POSTAGE
PAID
PERMIT NO. 21
Canton, New York
13617

NON-PROFIT
ORGANIZATION

PRE-PUBLICATION ANNOUNCEMENT

OLD HOLLYWOOD: The Story of the Jordan Club

In June or early July of this year the St. Lawrence County Historical Association will have the honor of publishing the first in an intended series of monographs on various aspects of county history: *Old Hollywood: The Story of the Jordan Club, 1890 to 1980*, by Lewis Fisher.

An Adirondack summer colony, the Jordan Club is located in Hollywood Township, Town of Colton, at the junction of two rivers, the Jordan and the Raquette. *Old Hollywood* tells the story of how the club lost its square-mile wilderness paradise and then regained it, somewhat altered; how a vast hydroelectric development turned a lovely, winding, island-studded segment of the Raquette into the bland waters of Carry Falls Reservoir.

Besides having spent most of his 81 summers and many of his winters at the Jordan Club, Lewis Fisher has other North Country roots. He was born in Canton in what is now the Phi Sigma Kappa House on Park Street. At that time his father, a nephew of Ebenezer Fisher, founding president of St. Lawrence University, was a professor in the Theological School on campus. Dr. Fisher became a member of the Jordan Club in 1902, and his son Lewis succeeded him as voting member in 1926.

Lewis Fisher has the essential gifts of a writer: a nimble way with words, the gift of observation, and the gift of imagery. His playful spirit transforms Old Hollywood into a wonderland for Alices, young and old.

The illustrated, paperbound edition of about 115 pages will have a list price of \$5.00 or \$4.50 for members of the Association; plus a handling charge of \$1.00 for mailing. Early subscriptions will help in defraying the cost of publication and in estimating the size of the edition.

Don't Feel Left Out; Join Us Now!

Regular Annual Membership	\$10.00
Sustaining Annual Membership	25.00

Send checks to:
SLCHA
P.O. Box 8
Canton, N.Y. 13617